



NORTHERN SPORTMOD - 2012

Revised October, 2011. Revisions/clarifications underlined, *recommendations italicized*.
Refer to www.imca.com for General Rules.

IMCA
1800 West D Street
P.O. Box 921
Vinton IA 52349-0921
319-472-2201 24-hour fax 319-472-2218
www.imca.com
raceimca@imca.com

The rules and/or regulations set forth herein are designed to provide for the orderly conduct of racing events and to establish minimum acceptable requirements for such events. These rules shall govern the condition of all events, and by participating in these events, all participants are deemed to have complied with these rules. NO EXPRESSED OR IMPLIED WARRANTY OF SAFETY SHALL RESULT

FROM PUBLICATIONS OF OR COMPLIANCE WITH THESE RULES AND/OR REGULATIONS. They are intended as a guide for the conduct of the sport and are in no way a guarantee against injury or death to a participant, spectator or official. The race director shall be empowered to permit reasonable and appropriate deviation from any of the specifications herein or impose any further restrictions that in his opinion do not alter the minimum acceptable requirements. NO EXPRESSED OR IMPLIED WARRANTY OF SAFETY SHALL RESULT FROM SUCH ALTERATION OF SPECIFICATIONS. Any interpretation or deviation of these rules is left to the discretion of the officials. Their decision is final.

No driver holding an IMCA license during the same calendar year in any other division may compete in this division, except: licensed Stock Car and Hobby Stock drivers (must still purchase SportMod™ license).

- SAFETY EQUIPMENT:** Rules apply at all times car is on track. Snell-rated SA2000, SA2005 or SA2010 helmet required. Roll bar padding required in driver compartment (*Fire retardant recommended*). SFI-approved full fire suit required. Fire retardant gloves, shoes and neck brace (or head and neck restraint) required. Right and left seat head supports required if using head restraint system with no neck collar. *Recommended: Fire retardant head sock and underwear; collapsible steering shaft.* Driver-side window net required, minimum 16 inch by 20 inch ribbon or mesh style, and must be mounted to roll cage so latch is at top front of window. Minimum three inch (two-inch with head restraint system) wide SFI-approved five point safety belt assembly required (Y-type shoulder harness not allowed), must be mounted securely to roll cage, *recommended to be no more than two years old*. Kill switch required within easy reach of driver and must be clearly marked 'OFF' and 'ON'.
- FRAME:** 1964 or newer OEM perimeter American rear-wheel drive passenger car frame only. No sports car frames. Frame must be full and complete, cannot be widened or narrowed, and must be able to support roll cage on both sides, exceptions are: weight jack in original center line of spring tower allowed; frame may be cut a maximum 36 inches forward from center of rear end housing; horns may be removed in front of steering box and notched maximum one inch at bottom for tie rod clearance; front crossmember may be notched and boxed for radiator and/or steering clearance; maximum seven inch wide opening in side of spring tower for spring removal. Maximum two inch wide by four inch tall frame stiffener may be welded directly to outside of left side frame rail. See www.imca.com for OEM frame dimensions. Minimum wheelbase 108 inches, maximum 112 inches, both sides. Maximum overall width shall not exceed 78 inches from outside of tire to outside of tire. For cars using OEM rear suspension design, rear of frame behind rear tires no further forward than one inch behind factory seam, may be replaced with two inch by three inch steel tubing with no 0.095 inch wall thickness. No part of frame can be lower than four inches from ground except front crossmember.
- ROLL CAGE:** Must consist of continuous hoops, minimum 1.75 inch O.D. tubing, with minimum wall thickness of 0.095 inch for main cage, frame-mounted in at least six places, *low carbon or mild steel recommended*. Must consist of a configuration of front, rear and top hoops connected by tubing on sides or side hoops. Driver's head must not protrude outside cage with helmet on. Roll cage must be securely supported and braced with minimum one cross bar in top halo. Foot protection bar required. Main cage no further forward than rear of engine. All bars forward of cage must be lower than hood.
- DOOR BARS:** All driver side door bars and uprights must be minimum 1.5 inch O.D. with 0.083 inch wall thickness. Minimum three driver side door bars, parallel to ground and perpendicular to driver, and welded to front and rear of roll cage. Passenger side must have at least one cross door bar, horizontal or angled, minimum 1.25 inch O.D. with 0.083 inch wall thickness, and one top door bar, minimum 1.5 inch O.D. with 0.083 inch wall thickness. Steel door plate, 18 gauge or 0.049 inch minimum thickness, must be securely welded to outside of driver side door bars and cover area from top door bar to bottom door bar and from rear hoop down-post to five inches in front of seat. Must be visible for inspection.
- BODY:** (See diagram) No composite or plastic body panels allowed except roof rock guard and hood scoop. Body must be same width, front to rear, and parallel to OEM frame. Aluminum nose panel must be flat. Maximum 2.250 inch side fins allowed on aluminum nose. MD3 plastic nose piece, part#020-410 allowed. All nose panels may be no wider, or lower than two inches outside of front frame horns and remain within 0.5 inch tolerance outside confines of front bumper. Plastic nose piece must be mounted in an approved manner and can extend no further back than 6 inches from front of hood. Cooling holes allowed. Engine compartment must remain open (no side panels). Hood must be level or sloped down at front, enclosed and flush with interior deck at rear. No reverse hood rake allowed. No panel in front of right door to engine compartment. No inner panels. No car covers. Must have front and rear roof support posts. Driver and passenger side windows must have at least 12 inch opening (height and width), measured at center of window, between lowest point at top and highest point at bottom. May use lexan in window side panels. Full size, fiberglass or aluminum roof only (see diagram). No dish roofs allowed. Driver roof hatch allowed. Maximum 1.5 inch rolled down rock guard allowed on roof front. Maximum four inch roof sides allowed. Maximum one inch ridge down sides of roof. Maximum one inch rear roof stiffener (must face down). Window side panels must resemble all aspects of drawing and may not extend ahead of back of seat. Rear spoiler (optional) may be minimum one inch to maximum five inches in material height and maximum 66 inches wide. Spoiler may have rear stiffener, must be one inch or more down from top. Maximum three spoiler braces allowed, must be mounted in line. Spoiler braces must resemble all aspects of drawing. Spoiler must be mounted within confines of spoiler braces. No fins, lips or wings allowed. No reflective doors or quarter panels. Tires must be widest part of car. Car number must be minimum four inches thick and 20 inches tall and clearly visible, on both sides, top and back of car, and front, if possible.
- DRIVER COMPARTMENT:** Must have minimum three windshield bars in front of driver. Lexan or aluminum cowl panel in front of driver can be no wider than cockpit and no farther back than steering wheel. Minimum 0.125 inch aluminum, or 0.060 inch steel, complete floor pan required. Aluminum high-back seat only and must be bolted in, using minimum 0.375 inch bolts, next to left side frame rail and ahead of rear tires. Bottom of seat can be no lower than bottom of frame rail. Driver must be sealed off from track, driveline, engine, fuel cell, canisters and pumps. Oil coolers must not protrude above interior. Accumulators cannot be mounted between driver and left-side door bars. No driver-adjustable devices allowed while car is in competition except brake adjuster. No mirrors of any kind.
- FRONT SUSPENSION:** All components must be steel, unaltered OEM, in OEM location, and replaceable by OEM parts, exceptions are: tube-type upper A-frames with or without aluminum or steel cross shaft, and mounts can be moved; OEM replacement stamped steel lower A-frames; rubber, nylon or steel lower A-frame bushings, no offset or bearing type; welded or bolted shock mount on lower A-frame; OEM, OEM replacement or rebuildable ball joints allowed. Lower A-frames must be right and left, and of same design. Lower A-frame mounts and bolt holes on frame must be in OEM location. OEM ball joints only. Sway bar must be unaltered OEM.
- STEERING:** No rack and pinion. All components must be steel, unaltered OEM, in OEM location, exceptions are: outer tie rod end and adjustment sleeve may be replaced by a minimum 0.625 inch steel rod end and steel tube; spindles can be ground for brake caliper clearance only; unaltered, OEM or OEM replacement Pinto spindles with 'IMCA' raised cast; bolt on spindle savers allowed; steel steering shafts and knuckles only driver compartment steering may be modified, must be kept on left side. Spindles must be right and left, and of same design. Quick release required - steering quickener and steering wheel may be aluminum. Idler arm, pitman arm, and center link must match frame.
- SHOCKS:** One steel, nonadjustable, unaltered shock per wheel only. All shock mounts must be welded. No shocks allowed on screw jacks. No external or internal bumpers or stops. No coil over, air, or remote reservoir shocks. No Schrader valves or bladder type valve allowed. Front half of any shock may be shielded. One or all shocks may be claimed per event for \$50 each, counting as one claim on card, following shock claim procedures (Refer to www.imca.com).
- SPRINGS:** One steel coil or multi-leaf (rear) spring per wheel only. Minimum 4.5 inches O.D., non-progressive coils only. No torsion bars, air bags or inner liners.
- REAR SUSPENSION:** All components must be steel. All mounts and brackets must be welded or bolted solid. Coil springs must remain vertical and over center line of rear-end housing. No coil-over eliminators allowed. No chains, cables or tethers. Rear shocks cannot be mounted on control arms. All rear control arms and panhard bars must be straight. Must utilize one of the following designs:
 - Aftermarket three link design requirements: Must use 16 inch minimum, 24 inch maximum lower control arms. Must use one upper control arm, solid tube only, located at top center of rear end housing and remain centered (one inch tolerance) on housing over drive shaft. Must use minimum 23 inch panhard bar located behind rear end housing. Lower spring perch must be welded to rear-end housing. Must use steel upper weight jack. No floating or bearing rear spring perches/cups allowed.
 - Multi-leaf spring design requirements: Must use steel multi-leaf springs with no additional suspension components besides one shock per wheel. Adjustable aluminum lowering blocks allowed.
 - OEM stock design requirements: Rear crossmember, control arm mounts and bolt holes on frame must be in stock location. All components must be unaltered, approved OEM, and match frame. Control arms cannot be altered in any way. Steel, rubber or nylon control arm bushings only. Springs must remain in stock location. Lower spring perch must be welded to rear-end housing. Must use steel upper weight jack.
- REAR END:** Any steel approved OEM passenger car or truck non-cambered rear end (housing and carrier) allowed, must be centered in chassis. All components must be steel, except lowering blocks, axle cap, and drive flange. Safety hubs (floaters) allowed. No quick change devices. One inch inspection hole in housing required. Mini-spools only. No torque dividing mini spools or differentials. Ring gear, center section and yoke cannot be lightened. Solid steel axles and one piece drive flanges only.
- BUMPERS:** (See diagram) Steel bumpers must be on front and rear at all times and welded, or mounted with minimum .375 inch bolts. Rear bumper must be constructed of solid square, or minimum 1.25 inch O.D. tubing with 0.095 wall thickness, and - similar to diagram - no wider than five inches outside of rear frame rails. If wider than five inches outside rear frame rails, must be capped and bent forward 90 degrees, or constructed in a loop design. Must have at least one upright, minimum 1.25 inch with 0.065 wall thickness, from bumper to fuel cell guard. Two-bar front bumper must be minimum 1.25 inch O.D. tubing with minimum 0.065 wall thickness (maximum 0.095 inch) mounted frame-end to frame-end, no wider than width of material outside frame horns and with bottom loop parallel to ground. Top bar must be directly above bottom bar, minimum 6.5 inches apart, measured center to center.
- TIRES/WHEELS:** Must use unaltered Hoosier Race tire, G60-15 with IMCA stamped on sidewall. No chemical softening, conditioning, or grooving of tires (Refer to www.imca.com for automatic penalties). Tires may be ground or siped within confines of tread (not past factory straight line). No re-caps. All wheels must be three or four inch backspace and display white 'IMCA approved' decal and wheel manufacturer decal. No wheel adapters, spacers or bleeder valves. May use IMCA approved bead lock, on right rear only. External, steel bead lock only and it cannot make wheel any narrower than 8 inches and no wider than 8.75 inches. Must use only steel bolts. Foam type or plastic outer mud cover allowed on right side wheels. Inner mud cover allowed on left rear only. Must use minimum one inch O.D. steel lug nuts.
- BRAKES:** Must be steel approved OEM, operative four wheel, drum or disc. Must maintain minimum OEM dimensions for hubs/rotors and calipers, cannot be lightened. No oil bath front hubs. Bolt pattern may be changed. Larger studs allowed. Rear rotors may be aftermarket 0.81 inch thickness (new). Vented rotors only, no scalloped or ceramic coated rotors. One proportioning device allowed (one-to-one ratio), front to rear only. Brake lines must be visible and must connect directly from master cylinder to calipers with no devices in between. Rear caliper brackets must be welded or bolted solid to rear-end housing.
- EXHAUST:** Round tube headers only. All primary header tubes must enter directly into one collector, at same point, at end of header. Collector length maximum 9 inches. Turn down (maximum 10 inches) allowed. Non-stepped headers only. No heat wrap, or exotic coatings on headers. Schoenfeld mufflers, stamped IMCA 609, must be used if track has noise reduction rule of 98 d.b. or more. All exhaust must go through mufflers, two per car, one per header. No exhaust sensors, merge collectors, cross-overs, extensions, inserts or balance tubes.
- FUEL SYSTEM:** Racing fuel cell required, maximum 32 gallon capacity (*12 gallon recommended*), must be in minimum 20 gauge steel container. Must be securely mounted behind rear axle, between rear tires, minimum four inches ahead of bumper, minimum 10 inches above ground. Must mount with minimum two solid steel straps around entire cell, two inches wide and 0.125 inch thick. All cell mounts must be steel, securely welded to frame/cage. Protective tubing must cover rear and extend past both sides of cell. No part of cell shall be lower than protective tubing. Fuel cell vents, including cap vent, must have check valves. If fuel cell does not have aircraft style positive seal filler neck/cap system - a flapper, spring or ball type filler rollover valve is required. Pick-up must be on top or right side of cell. One fuel filter allowed. No cool cans. Air cleaner top/stud cannot direct air into carburetor. No top flow air cleaner housings. Mechanical OEM type push rod fuel pumps only. Maximum 0.100 inch thick carburetor gaskets on all engines. **CLAIM ENGINE:** must use IMCA approved naturally aspirated, unaltered 500 c.f.m. Holley - part no. 0-4412, may be modified to Holley HP Dorton part no. 0-80583-1 specs only. Float bowl must face forward. Any adapter, maximum one inch thick. No throttle bore adjustable carburetor spacers. **GM CRATE ENGINE:** may use any Holley 4 barrel carburetor, all components (float bowls and main body) must be Holley manufactured. Metering blocks and base plate may be billet aluminum non-Holley. No aerosol-style carburetors allowed. May use Speedway Motors part #545-64940 or Moroso part #64940 carburetor spacer on crate. All carburetors, may be exchanged, style for style only, following same procedure as engine claim. Driver claiming carburetor may not claim engine or shocks on same night.
- FUEL:** Gasoline only. Racing fuel allowed. No E85. *Pump grade recommended.* No performance enhancing or scented additives. Fuel must pass both dielectric meter and chemical tests. Fuel sample may be taken from any car at any time (Refer to www.imca.com for automatic penalties).
- WEIGHT:** Minimum weight limit of 2,500 pounds, no tolerance, after race with driver in car. Weights must not be used in driver compartment or outside body. All weights must be securely mounted with at least two 0.5 inch bolts, painted white with car number on it. No titanium, magnesium, stainless steel or carbon fiber components. Solid steel fasteners only.
- BATTERY/STARTER:** One 12 volt battery only, must be securely mounted between frame rails, and positive terminal must be covered. Starter must bolt on block in OEM location and directly

- engage flexplate/flywheel. Car must have capability of starting without being pushed or pulled. Car must leave initial staging area on demand, unaided, or go to rear of that race.
21. **GAUGES/ELECTRONICS:** No unapproved cameras, transmitting or listening devices (exception is one-way RACEceiver radio by officials), timing retard controls, or digital gauges (including tach). No electronic monitoring computer devices capable of storing or transmitting information except memory recall analog tach. 12 volt ignition system and OEM HEI distributor only. Ford/Chrysler may use HEI distributor. No billet distributors or crank triggers. Ignition rotor, cap, coil and module must remain OEM appearing. Crate engine **MUST** use MSD #8728 rev-control and 6,200 rpm chip. Claim engine **MAY** use MSD #8728 rev-control with any rpm chip. Rev-control must be out of reach of driver, but accessible for inspection with rev limiter facing upward. No ignition boxes, remote coil or accessories. All wiring must be visible for inspection. Only gauges allowed are analog oil pressure, fuel pressure, brake bias, water temperature and tach. OEM type alternator with internal regulator allowed. No electronic traction control devices (Refer to www.imca.com for automatic penalties).
 22. **TRANSMISSION/DRIVE SHAFT:** All forward and reverse gears must be operational, plus a neutral position. With engine running and car in still position, driver must be able to engage car in gear and move forward, then backward. Only OEM production transmissions allowed. No 'in and out' boxes or quick change devices allowed. Functioning shift levers must be in OEM location. One steel or aluminum OEM style/size flywheel or steel OEM style/size flexplate allowed, must be bolted directly to end of crankshaft.

Automatic: Must be unaltered, two or three speed, OEM production case with a functioning OEM appearing pump. Aluminum OEM bellhousing may be replaced with aftermarket explosion-proof aluminum bellhousing. Original OEM bellhousing must have approved scattershield constructed of minimum 0.125 inch by three inch steel, 270 degrees around flexplate. Only external lines allowed are for transmission cooler. Splined drive flange coupler or torque converter (10 inch minimum) only.

Manual: Must be unaltered, three or four speed, OEM production case and have a working 7.25 inch minimum diameter, steel and/or aluminum, single or multi-disc clutch and pressure plate bolted directly to flywheel/flexplate. These components must rotate, consistent with engine rpm, while car is in any gear. Must use explosion-proof steel bellhousing with one hole for throw out bearing lever or hose, must be 270 degrees around top of clutch and flywheel/flexplate area. Hydraulic clutch pedal allowed with manual transmission only.

Drive Shaft: Minimum two inch diameter, white, steel drive shaft. Steel slip-yokes only. 360-degree drive shaft loop required and must be constructed of at least 0.25 inch by two inch steel, or one inch tubing, mounted six inches back from front U-joint.
 23. **ENGINE COMPARTMENT:** Rear of engine (bellhousing flange) must be mounted at least 72 inches forward from centerline of rear axle. Engine offset must be kept within two inches of centerline of front crossmember with engine level. Minimum 11 inch engine height from ground to center of crankshaft. V-belt aluminum or steel pulleys only. Copper/brass or aluminum radiator only and must be mounted in front of engine. No vacuum pumps, pan evap systems, oil coolers or remote oil filters.
 24. **ENGINE OPTIONS AND SPECIFICATIONS:** All cars must clearly display on driver side front roof post which engine they are competing with. Must be contrasting in color from body, minimum 2-inches tall and display **CLAIM or CRATE. Markers not acceptable.**

(A) CRATE ENGINE: Must use unaltered sealed GM #88958602 or #19258602 crate engine. Upon inspection, any different, altered or missing GM seal bolts will result in disqualification, loss of all IMCA points for the season, \$1,000 fine and a one year suspension from all divisions with crate option. GM seal bolt exception is IMCA approved and issued cable-lock rebuild system, and oil pan may be replaced by IMCA certified repair center with Kevko pan #1090NRHw/ISP and Kevko pick-up #1003-3/4. \$250 fine for any crate engine not using required spacer, distributor, rev limiter, pushrods, valve springs or rocker arms. Any driver using crate engine cannot claim engine or have engine claimed. During same season, no driver is allowed to claim an engine after competing with a crate. If a driver switches to a crate after claiming an engine, the crate engine is then claimable.

(B) CLAIM ENGINE: All engines must be able to be used in conventional passenger car without alterations. External engine casting and threaded holes cannot be altered.

BLOCK: OEM steel passenger vehicle production block only. No GM Bowtie, Ford SVO or Chrysler W components allowed. GM approved block numbers are: 3892657, 3914660, 3914678, 3932388, 3932386, 3956618, 3970000, 3970006, 3970010, 3970014, 10066033, 10066036, 10243880, 14010207, 14010209, 14010287, 14016376, 14016379, 10054727, 14088528, 14088548, 14088552, 14093638, 14101148. Stroke must match block. No 400 or larger cubic inch parts allowed. Maximum 361 cubic inches (GM); 363 (Ford); 370 (Chrysler). Violation of cubic inch limit must be verified by removal of head and will result in disqualification, loss of all IMCA points for the season, \$1,000 fine and a 30-day suspension. Maximum compression ratio is 9.0 to 1, no tolerance. Compression ratio checked using Whistler and cubic inches checked using pump, OR by visual inspection of part and/or casting numbers, pistons, etc (track option which method is used). Flat top or dished pistons only, no gas-ported pistons. OEM or OEM replacement steel crankshaft only - cannot be lightened. No aerowing, bullnose, knife edge, undercut or drilling of second or third rod throws. OEM or OEM replacement steel rods only - GM 5.7 or 6-inch rod allowed. Cap screw allowed. Conventional flat tappet cam and lifters only, cannot alter lifter bores. OEM firing order cannot be changed (GM: 1-8-4-3-6-5-7-2). May use oil restrictors. 'Wet' sump oiling system only. Steel oil pans only. Racing oil pans allowed. Mandatory one inch inspection hole in all pans - no obstructions to crank and rods. Accumulator allowed.

CYLINDER HEADS: Steel only. Must be unaltered approved OEM and minimum 76 cc combustion chamber (GM). Only GM OEM approved head numbers are: 14079267, 3986336, 3986339, 3986339X, 3986388, 3932441, 376445, 3928454, 3932454, 3876487, 3973487, 3973487X, 3973493, 3951598, 468642, 330862, 333882, 3998920, 3998991, 3998993, 3998997, 3970126. Maximum size valves on these heads are 2.02 inch intake and 1.60 inch exhaust. May use Engine Quest (EQ) Stock Replacement (SR) cylinder head, GM part number CH350L, Chrysler part number CH318B; head must remain as produced, seat angles and valve sizes can not be changed: three angle valve job only (absolutely no casting removal in valve pocket of EQ head, for any reason); Ford - no after market or SVO heads; Chrysler - no after market or W-2 heads, 360 cubic inch heads only. No porting, polishing or unapproved alterations allowed to any cylinder head or intake, disqualification and \$250 fine if illegal. Guide plates, screw-in shouldered studs (GM 0.375-inch max) and polylocks allowed. No stud girdles. Steel roller tip rocker arms allowed. GM - 1.250 inch maximum O.D. valve springs, no beehive valve springs allowed.

INTAKE: Unaltered, approved OEM cast iron low rise, two- or four-barrel. Only unaltered (no porting or polishing) aftermarket aluminum intakes allowed are: Weiland GM #7547, #7547-1; Ford #7515, #8023 or #7516; Chrysler #7545, #8022; Edelbrock GM #2701; Ford #7121, #7181, #7183; Chrysler #2915. Cooling lines allowed on aluminum intakes. Disqualification, loss of points, purse and \$250 fine if any alterations are found to heads/intake. Unaltered OEM type harmonic balancer only. OEM type steel or aluminum water pumps only.
 25. **ENGINE CLAIMING RULES:** Refer to www.imca.com for claim eligibility requirements.

(A) \$550 cash claim on engine, \$25 goes to wrecker for pulling engine and \$25 goes to official.

(B) Claim does not include - 1. flywheel, 2. clutch, 3. pressure plate, 4. bellhousing, 5. breathers, 6. carburetor, 7. starter, 8. motor mounts, 9. oil/temp. sending units, 10. fan and pulleys, 11. clutch ball, 12. clutch arm, 13. throw out bearing, 14. dip stick, 15. water pump, 16. fuel pump, rod and plate, 17. distributor, 18. plug wires, 19. water outlet and restrictor, 20. headers.

NOTE: During engine claim, block and head numbers should be verified, heads, intake, connecting rods and crankshaft should be visually inspected and one spark plug must be removed to check flat top or dish pistons prior to transfer of engine to claiming driver. If, at this time, engine is found illegal, claimed driver is disqualified and suspended from all IMCA sanctioned events until such time as a \$250 fine is paid, for first offense. Claimer then has option to accept or decline engine - if declined, driver is not charged with claim. Second offense penalties will be \$500 fine and/or suspension.
 26. **POINT STRUCTURE /PROCEDURES:** Refer to www.imca.com.
 27. **EIRI:** (Except in rare instances) Decisions of officials are final and binding without exception. In some cases, track safety rules may take precedence over IMCA rules - any discrepancy between IMCA and track rules should be brought to the attention of IMCA. Any rule changes or clarifications during the course of the year will be amended at www.imca.com as well as published in **Inside IMCA**, the official newsletter of IMCA, and will be considered as an official part of these rules.

For more information, call Tom Gutowski at 402-350-6120, or IMCA at 319-472-2201.

Copyright© 2012 IMCA. All rights reserved.

No part of this publication may be reproduced, stored, or transmitted in any form, without prior written permission.

IMCA Northern SportMod Body Dimensions For 2012

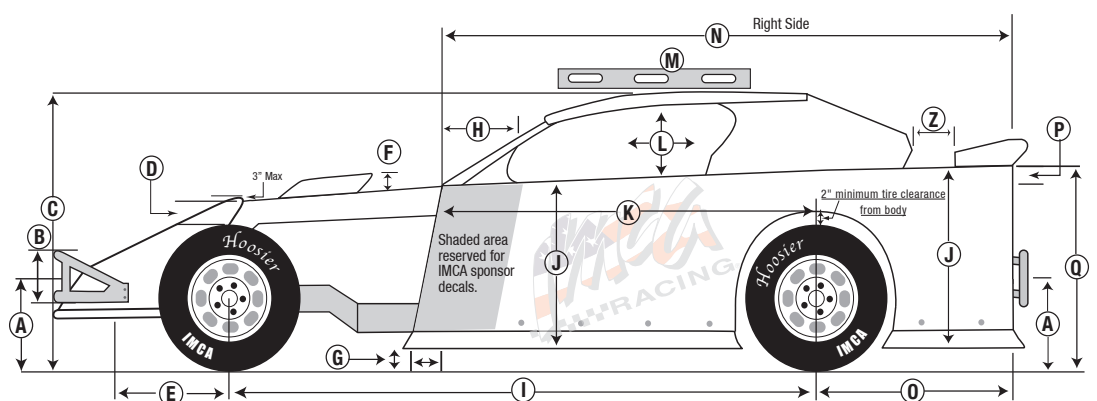

All body measurements are max. unless otherwise specified. Dimensions have zero tolerance.

- A** 20" max. 16" min. (ground to center of bumpers, front and rear)
- B** 6.5" min. (center to center)
- C** 54" max. 42" min.
- D** Hood 6" max. drop (sides), sealed off from driver's compartment and max. 3" rake.
- E** 42" max.
- F** 6" max.
- G** 4" min. Door may be extended maximum 6" past block at bottom on both sides.
- H** 19" max., must be same on both sides.
- I** 112" max. 108" min.
- J** 31" max. 22" min.
- K** 72" max. or not past back of block, right side. Left side may extend forward to cover foot box.
- L** 18" max. 12" opening, both sides.
- M** With level, must have no more than 2" clearance at rear of roof and 5" at front.
- N** 120" max. 106" min.
- O** 48" max. 34" min.
- P** Interior slope is 6" max. front to rear and flat across. If flat at front half of interior you have used up 50% of your 6" so from behind driver to rear you may only have 3". Top of interior must be flush with top of doors and quarters. Optional escape hatch from driver to passenger door allowed.
- Q** 38" max. 28" min.
- R** Min. 24" nose must be flat and flush with sides.
- S** 66" max. 24" min. must cover radiator.
- T** 52" max. 44" min.
- U** 56" max. 41" min.
- V** All tires must be outside body and nerfbar and visible from front, rear & top.
- W** 66" max. 53" min. same front to back
- X** 43" max. 24" min.
- Y** IMCA decal required on filler panel.
- Z** 3" minimum
- REAR FILLER PANEL:** 8" min. /90 degree angle. Must be solid, attached to deck, extend to quarter panels, securely fastened.
- SPOILER BRACES:** Maximum 3 total. Bottom edge of spoiler brace must be flush with rear edge of interior deck.
- SAIL PANELS:** Must be within confines of these dimensions and the same on both sides. Must mount within 2" of outside edge of interior deck.

